

Dimensjonering av infiltrasjonsanlegg ved bruk av infiltrasjonskammer

Ved dimensjonering av infiltrasjonsanlegg med infiltrasjonskammer anbefaler VA-systemer AS en reduksjon av grøftelengde på inntil 30% i forhold til standard pukkfylling. Bakgrunnen for dette er en konservativ videreføring av anbefalinger fra produsent av kamrene som opererer med en reduksjon på opp mot 50%.

Infiltrasjonskamrene produseres av firmaet Infiltrator[®] i USA og de har siden oppstarten i 1987 levert over 1,5 millioner kammerbaserte infiltrasjonsanlegg. I USA alene installeres det hver måned ca. 20 000 Infiltrator[®] anlegg, noe som utgjør en markedsandel på 30%.

Siden høsten 2005 er det lagt ned ca. 400 anlegg her i landet, fordelt på ca. 25 kommuner. Flere av disse er installert med inspeksjonsrør. Vi har ikke fått negative tilbakemelding på noen av disse installasjonene.

Kan grøftelengde reduseres ved bruk av infiltrasjonskammer i forhold til pukkløsninger?

Behandling og infiltrasjon av avløpsvann avhenger av:

- Mengde og type avløpsvann
- Midlertidig lagringskapasitet
- Permeabilitet til stedlig masse
- Tilgjengelig areal for infiltrasjon

Mengde og type avløpsvann er en faktor som gir lite rom for påvirkning i et standard infiltrasjonsanlegg med mindre spesielle rensemetoder kreves.

Infiltrasjonskammer har god midlertidig lagringskapasitet ved at ett standard kammer rommer et volum på 132 liter pr. løpemeter. Dette tilsvarer et volum av pukkløsning på 0,53m³ gitt 25% porevolum. Med et beregnet forbruk av pukkløsning på 0,32m³ (90cm x 35cm) pr. løpemeter gir en pukkløsning derved 40% dårligere midlertidig lagringskapasitet enn ved bruk av Infiltrasjonskammer. Forsøk utført ved Clemson University viser at midlertidig lagringskapasitet for pukkløsning er ennå lavere i forhold til for Infiltrasjonskammer, og i realiteten ligger på rundt 50% (vedlegg nr.1).

Permeabilitet av stedlig masse er en konstant faktor som direkte vil påvirke Infiltrasjonsanleggets dimensjonering basert på synkeprøve..

Den faktor som enklest kan påvirkes av utbygger er tilgjengelig areal for infiltrasjon.

Med utgangspunkt i Darcy's lov for strømming i porøse media, vil en økning i tilgjengelig areal gi en proporsjonal økning i strømningsrate;

$$Q=KiA$$

der	Q	=	strømningsrate
	K	=	hydraulisk konduktivitet
	i	=	hydraulisk gradient
	A	=	areal

Bruk av Infiltrasjonskammer gir mest tilgjengelig areal for infiltrasjon pr. løpemeter sammenlignet med andre infiltrasjonsløsninger. Infiltrasjonskamrene har en åpen bunnflate som ikke gir noen restriksjon mot infiltrasjonsarealet, mens en pukkløsning vil gi blokkering av infiltrasjonsflate overfor stedlig masse pga. at matriks i pukken vil dekke store deler av infiltrasjonsarealet. Sidespalter øker infiltrasjonsarealet ytterligere, og optimaliserer derved infiltrasjonsevnen for Infiltrasjonskammer.

Egenvekt av pukkløsning med tilleggsvikt fra overdekning gir kompaksjon av eksisterende masse i bunnen av grøften. Dette fører til redusert permeabilitet og derved ytterligere reduksjon av infiltrasjonsevnen til infiltrasjonsområdet (vedlegg nr.2).

Bruk av Infiltrasjonskammer reduserer/fjerner denne kompaksjonen og derved beholdes opprinnelig infiltrasjonspotensiale for eksisterende masse i kontaktflaten.

Holdbarhet for infiltrasjonsanlegg med infiltrasjonskammer i forhold til pukkløsninger?

I et anlegg med Infiltrasjonskammer vil det bli en jevn distribusjon av avløpsvann over hele infiltrasjonsarealet etter hvert som en aktiv biomatte opparbeides. System med perforert rør/pukk skal fungere på lignende måte slik at avløpsvann jevnt fordeles over hele infiltrasjonsgrøften, men dette forutsetter at perforeringen (eks. 8mm hull med 1m mellomrom) ikke tettes av smuss eller løsmasser. Sammenlignet med bruk av Infiltrasjonskammer vil bruk av perforert rør gi en økt risiko for ujevn fordeling av avløpsvann over infiltrasjonsområdet, og kan derved redusere infiltrasjonsanleggets levetid (vedlegg nr 3). Infiltrasjonsanlegg med Infiltrasjonskammer der grøftelengen er redusert 50% visere en lavere feilrate i forhold til standard pukkløsning. Studie utført på 389 anlegg i Oregon viser en feilrate for pukkløsninger som ligger på 1,6%, mens feilrate for anlegg med Infiltrasjonskammer der grøftelengde er redusert til halvparten er 1%. Kriteriet for feil var synlig avløpsvann på overflate (vedlegg nr.4).

Emil Skottlien
Sivilingeniør
VA-systemer AS



VA-systemer AS
2680 Vågå
e-mail: va-systemer@va-systemer.no
www.va-systemer.no

Vedlegg:

Vedlegg nr. 1: "In-situ Volume Measurements on Drainline Products".

Forsøk utført ved Clemson University i Clemson South Carolina, viser at standard (Q4) Infiltrasjonskammer har en lagringskapasitet pr. løpemeter som er over dobbelt så stor som et pukkvolum på $0,32\text{m}^3$.

Vedlegg nr. 2: Wastewater Infiltration into Soil and the Effects of Infiltrative Surface Architecture" utført ved Colorado School of Mines i Golden Colorado, viser infiltrasjonsevne for en kontaktflate under påvirkning av tett matriks (f.eks. pukk). Forsøkene viser at en upåvirket kontaktflate vil være fordelaktig for å optimalisere infiltrasjonsevnen. Dette oppnås ved bruk av Infiltrasjonskammer.

Vedlegg nr. 3: "Effluent Distribution in Chambers and Perforated Distribution Pipe", viser observasjoner rundt fordeling av avløpsvann i system med hhv. perforert rør/pukk og Infiltrasjonskammer.

Vedlegg nr. 4: "Surface Failure Rates of Chamber and Traditional Aggregate-Laded Trenches in Oregon", viser feilrate for infiltrasjonsanlegg med Infiltrasjonskammer der grøftelengden er redusert med 50% i forhold til pukk løsninger. Ut av 389 anlegg, derav 198 med Infiltrasjonskammer og 191 med pukk løsning, ligger feilraten på hhv. 1% for Infiltrasjonskammer og 1,6% for pukk løsning.

Test Summary



“In-situ Volume Measurement of Drainline Products”

December 2004

Clemson Study concludes chambers provide twice the storage capacity as comparable stone trench

Study Summary

A 2004 field study by the Clemson University Department of Entomology, Soils, and Plant Sciences measured the in-situ liquid storage capacities of chambers, multi-pipe systems, and synthetic aggregate bundles, as compared to a conventional, 36-inch-wide, 14-inch-high stone trench. The study showed substantial differences in storage capacity between manufactured drainfield products and the stone trench. *Table 1* and *Figure 1* show storage capacities for the products tested.

Infiltrator® Systems, Inc. (ISI) products provide a storage capacity that exceeds the storage capacity of a comparable width stone trench. ISI's Standard chamber models, designed for installation in a 36-inch-wide trench, provided more than two times the storage of a 36-inch-wide stone trench at the inlet pipe invert height. ISI's Equalizer® 36 chamber model, designed for installation in a 24-inch-wide trench, provided a total storage capacity equal to a 36-inch-wide stone trench at the inlet pipe invert height.

Table 1: Total and Inlet Pipe Invert Storage Capacity

Drainfield Product	Total Capacity (gal/ft)	Invert Capacity (gal/ft)
ISI Standard chamber	13.3	10.2
ISI Quick4 Standard	11.7	10.7
ISI Equalizer 36 chamber	10.2	9.3
36" W x 14" H stone trench	10.2	4.7
PTI MPS-10	9.4	8.6
PTI MPS-9	8.2	5.6
EZflow 1402HP	7.4	2.8
EZflow 1203H	6.1	1.7
ISI Equalizer 24 chamber	5.4	4.5
EZflow 1401	3.8	1.4
EZflow 1201	2.9	1.1

Figure 1: Total and Inlet Pipe Invert Storage Capacity

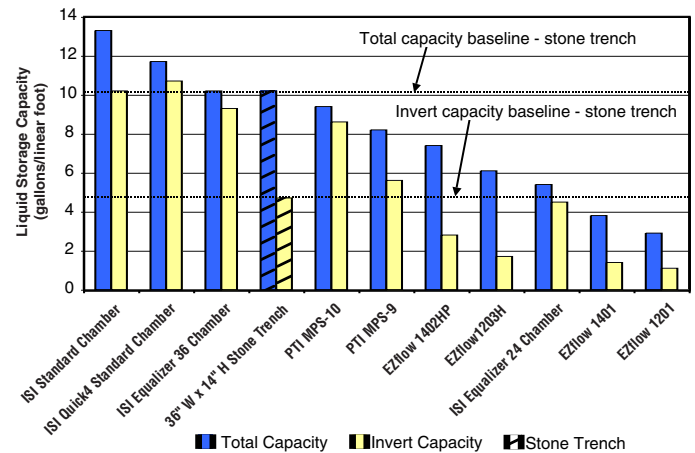

Benefits of Added Drainfield Storage Capacity

How much did each chamber deflect at the AASHTO H-10 axle load?

- It provides temporary storage during peak flow periods, such as heavy loadings from frequent laundry usage; heavy loadings from extended showers; large social gatherings and combinations of the above events.
- It provides temporary storage during seasonal wet periods when infiltration rates diminish due to a decrease in hydraulic gradient.
- Greater storage volume equates to more air within the drainfield, allowing for the potential of greater oxygen transfer to the absorption system.

How does Infiltrator's chamber storage capacity compare to a conventional stone trench?

- Standard chamber model (34 inches wide): 1.3 times more storage than a 36-inch-wide stone trench at full capacity; 2.1 times more storage than a 36-inch-wide stone trench at the invert capacity.
- Equalizer 36 chamber (22 inches wide): Equal in total capacity to a 36-inch-wide stone trench; 1.3 times more storage than a 36-inch-wide stone trench at the invert capacity.

How can added storage capacity benefit designers and installers that chose Infiltrator System's chambers?

- Increased factor of safety against drainfield failure.
- Increased ability to handle flow variations and periodic heavy use.
- Decreased potential for ponding at the ground surface during seasonal wet periods.
- Added protection against liability associated with drainfield failure.
- Superior drainfield system performance compared.

“In-situ Volume Measurement of Drainline Products”

December 2004

Test Procedures

Step 1: Trench is excavated for in-situ drainfield product installation.

Step 2: Trench bottom is leveled to support drainfield product.

Step 3: Drainfield product is equipped with plastic tubing to allow displaced air to escape during liquid filling.

Step 4: Visual markers (see arrows) are installed to provide a reference point at the invert and total liquid fill heights.

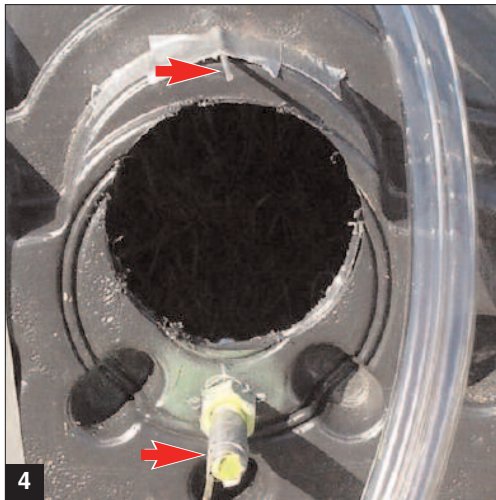

Step 5: A plastic membrane is wrapped around the drainfield product to retain water during liquid filling.



Step 6: The drainfield product is backfilled; inspection port for observing liquid fill level is provided; and plastic tubing allows displaced air to escape to the atmosphere during filling.



www.infiltratorsystems.com

1-800-221-4436

RESEARCH SUMMARY

“Wastewater Infiltration into Soil and the Effects of Infiltrative Surface Architecture”

Colorado School of Mines Concludes Chamber Trench Sizing Can Be Smaller Than Aggregate Trench Sizing

Researchers at the Colorado School of Mines (CSM) in Golden, Colorado have measured the effects of the infiltrative surface architecture (ISA) on the infiltration of septic tank effluent (effluent) within a wastewater soil absorption system (absorption system). The ISA represents the physical characteristics and attributes of the interface between the absorption system and underlying soil. The focal point of three CSM studies (see reverse side) was quantifying infiltration rates for ISAs that were obstructed with aggregate (gravel or other solid objects) and unobstructed (chambers). These studies showed that aggregate in the infiltrative surface reduces the unobstructed soil pore network accessible for effluent infiltration and movement (**Figure 1**). Effluent passing through an aggregate-obstructed infiltrative surface must be processed through a smaller volume and more complex open soil pore network, as compared to an aggregate-free infiltrative surface. This results in a loss of hydraulic conductivity, and correspondingly, infiltrative capacity.

CSM researchers quantified the difference in infiltrative capacity between an aggregate-obstructed infiltrative surface and an aggregate-free infiltrative surface. This work showed that 1.5 to 2.0 times more effluent flows through an unobstructed infiltrative surface than an obstructed infiltrative surface (mature system in sand and sandy loam soils). This shows that a chamber system can be sized with a smaller soil infiltration surface area than that of a gravel-filled (or other solid object) system.

Figure 1: Conceptual model depicting the effects of solid objects (gravel or synthetic aggregate) on the infiltrative surface.

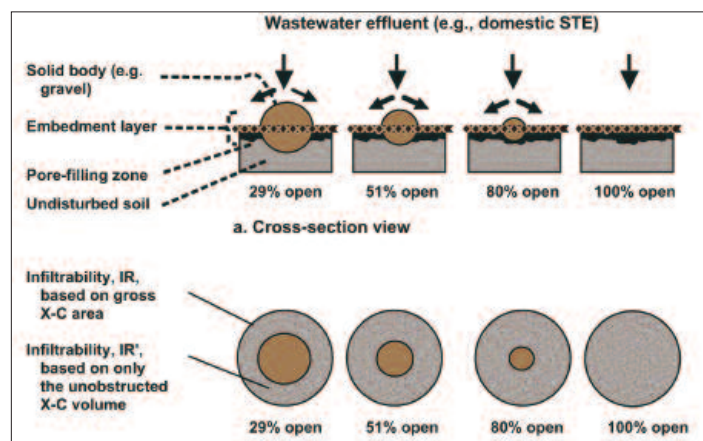
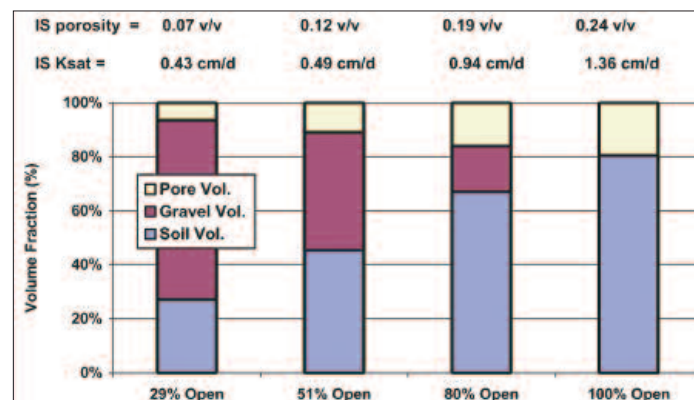

Figure 2: Graphical illustration of relative pore, solid object, and soil volumes for a 0.2-inch-thick section of infiltrative surface for the conceptual models shown in Figure 1.



What is the “Infiltrative Surface Architecture” or ISA?

- Interface between the wastewater absorption system and soil
- Biologically active zone (biomat), objects contacting native soil in the trench, and native soil surface
- Zone where septic tank effluent enters the soil within a wastewater soil absorption system
- Physical attributes such as depth, geometry, soil pore sizes, and soil pore network configuration

How can the ISA become obstructed?

- Certain absorption system media cause solid objects (e.g., natural or synthetic aggregate) to embed within the trench bottom (**Figure 1**)
- Embedment is due to dumping gravel or other solid objects, overburden stress, and intermittent wetting cycles
- Embedment layer becomes a mixture of solid objects and soil of varying proportions (See example proportions in **Figure 2**)

What are the effects of an obstructed ISA?

- Smaller pore sizes and increased water flowpath complexity
- Decreased unsaturated hydraulic conductivity, and correspondingly, diminished infiltrative capacity

How much effect does an obstructed ISA have on infiltration?

- For a mature wastewater system, effluent flow through an open infiltrative surface (e.g., chamber) is 1.5 to 2.0 times higher than flow through an obstructed infiltrative surface (e.g., gravel or synthetic stone)

What do these research findings mean for chamber systems?

- A chamber wastewater soil absorption system can be sized with a smaller soil infiltration surface as compared to that required for a gravel (or synthetic stone) trench

“Wastewater Infiltration into Soil and the Effects of Infiltrative Surface Architecture”

Colorado School of Mines Study Summaries

Laboratory Experiment #1 – Gravel-Laden and Gravelless System Biomat Evolution and Hydraulic Conductivity

Method

- Sand columns simulate gravel-laden and gravelless trenches (**Figure 3**)
- Hydraulic conductivities measured using clean water and septic tank effluent

Findings

- For clean water, gravel-laden and gravelless hydraulic conductivities were similar
- For septic tank effluent, mean infiltration rates (IRs) were:
 - Gravel-laden sand column – 0.70 gal/day/square foot
 - Gravelless sand column – 1.16 gal/day/square foot
- Gravelless IR was 1.6 times higher than gravel-laden IR

Figure 3: Sand column apparatus for gravel-laden and gravelless infiltrative surface hydraulic conductivity testing.

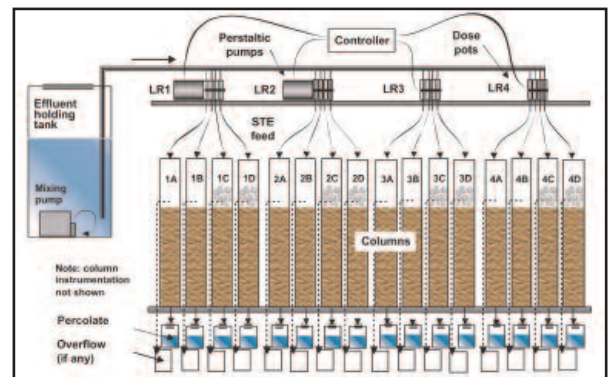

Laboratory Experiment #2 – Effect of Solid Objects within the Infiltrative Surface on Infiltration Rates

Method

- Gravel simulated using manufactured glass spheres
- Sand columns containing 29%, 51%, 80%, and 100% open area
- Infiltration rates measured using wastewater surrogate material

Findings

- Greatest infiltration rate observed in columns with greatest percentage of open area (**Figure 4**)
- Solid objects within infiltrative surface reduced the infiltration rate in proportion to the amount of area obstructed by solid objects

Figure 4: Infiltrative rate results by percent open soil surface.

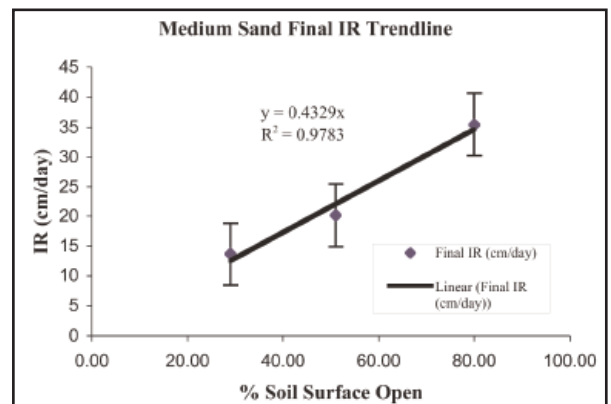

Field Experiment #1 – Hydraulic Performance of Three Infiltrative Surface Architectures

Method

- Pilot-scale field test cells using chamber, gravel, and synthetic stone infiltrative surface architectures in a silty loam soil
- Test cells loaded using septic tank effluent at 1.0 and 2.0 gpd/ft² until predefined hydraulic failure occurs (by ponding height for three consecutive weeks)
- Infiltration rate changes measured with time

Findings

- Solid objects within infiltrative surface reduced test cell’s infiltrative capacity
- Wastewater ponding heights were higher with solid objects present in the infiltrative surface (**Figure 5**)
- Predefined hydraulic failure occurred sooner when solid objects present within the infiltrative surface

Figure 5: Ponding height and hydraulic failure data for field test cells loaded with specific tank effluent.

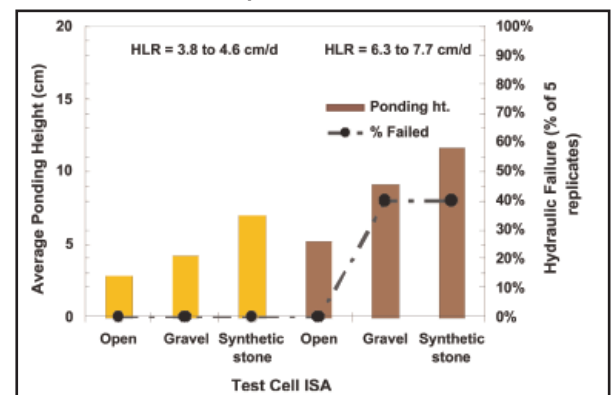

RESEARCH SUMMARY

Effluent Distribution in Chambers and Perforated Distribution Pipe

Multiple studies conclude that perforated distribution pipe does not provide “equal distribution” within gravity fed onsite wastewater trenches.

Wastewater Distribution within a Chamber Trench

Research on the distribution of septic tank effluent within a trench system (gravity flow) demonstrates that uniform distribution across the trench bottom is achieved without a perforated pipe. As wastewater enters the chamber at the inlet end, it flows over the biomat which has formed on the trench bottom. This biological growth forms progressively from the inlet end of the trench and extends to the full trench length to form a mature on-site system (Figure 1). Due to the relatively low permeability of the biomat, wastewater typically ponds achieving a uniform elevation along the trench length. The biomat provides infiltration along the entire length of the trench, and is the mechanism by which uniform distribution is achieved. Therefore the biomat provides equal distribution, not the perforated pipe.

Wastewater Distribution within a Gravel and Pipe Trench

The mechanisms that provide distribution of septic tank effluent in a chamber trench are identical to the mechanisms working within a gravel and perforated pipe trench flowing under the force of gravity. As with chambers, water enters the stone and pipe trench at a single point. Due to the low flow rates (approximately 1.6 gallons/minute at peak flow, which is washer discharge) wastewater discharges from a single location along the perforated pipe (Figure 2). The single discharge location may correspond to either a low point along the axis of the pipe (perforations oriented in the 4 and 8 o'clock positions), or the first few perforations that wastewater encounters upon entering the pipe (perforations oriented in the 6 o'clock position). From the point discharge location, distribution within the drainfield is provided by the biomat, as discussed above for a chamber system.

Figure 1: Progressive Clogging of the Infiltrative Surfaces of Subsurface Absorption Systems (Bouma et al. 1972)

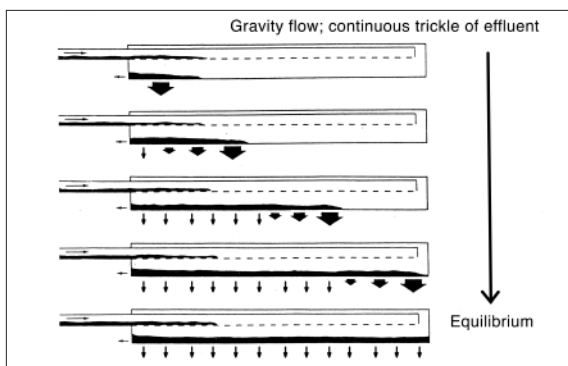
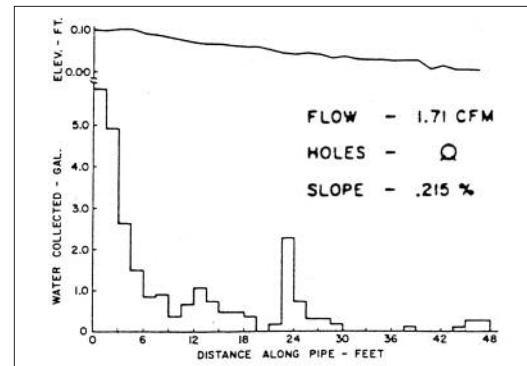

Figure 2: Distribution of Water Pumped at 12.71 gpm Along a 4-inch Perforated Bituminous Pipe (Converse 1974)



Does a chamber provide uniform distribution on the trench bottom under gravity flow?

- Yes, chamber systems with a mature biomat provide uniform distribution of septic tank effluent.

How is septic tank effluent distributed in a chamber under gravity flow?

- From the inlet location a biomat is formed, then effluent flows over the biomat and ponds with increased system usage/age.
- As the biomat matures toward the end of the trench, effluent continues to follow the “path of least resistance” until effluent equilibrium is achieved.
- As the effluent level in the chamber fluctuates, ponding occurs, with wastewater equalizing at a uniform elevation along the trench axis.
- For a ponded condition, water covers the entire trench bottom, providing uniform distribution.

How does effluent distribution compare for a chamber vs. stone and perforated pipe?

- Under gravity flow, these systems work based upon the same principles that biomat provides equal distribution.
- Water flows from the inlet point over the biomat, to a uniform ponding height, which results in even coverage of wastewater over the trench bottom.

Doesn't perforated pipe distribute water along the entire trench?

- No – perforated pipe provides a point discharge.
- For holes oriented downward (6 o'clock position), wastewater flows out of the first several holes at the inlet end of the trench. This is due to the low flow rates within the 4-inch-diameter pipe.
- For holes oriented on the sides of the pipe (4 and 8 o'clock positions), wastewater flows out of the holes located at the low point along the pipe, which is where wastewater accumulates, until reaching a level where it flows out of the holes.

Effluent Distribution in Chambers and Perforated Distribution Pipe

Documentation of Wastewater Flow in Perforated Pipe

Results of study by Machmeier and Anderson, "Flow Distribution by Gravity Flow in Perforated Pipe":

- "The term 'distribution pipe' as used for the pipe now commonly installed in drainfield trenches or seepage beds is definitely a misnomer with reference to liquid distribution."
- "With one row of perforations at the 6 o'clock position, effluent will be discharged into the drainfield rock near the head of trench or bed."
- "With perforations at the 4 and 8 o'clock positions, and the pipe absolutely level...effluent will concentrate at some random location where the perforations are at the lowest elevation."
- "If a pipe has a uniform slope it will concentrate at the far end."
- "...it is not likely that a perforated pipe will be installed as carefully in the field as for these tests, resulting in a random location for the concentration of effluent."
- "If pipe is necessary in a drainfield trench, it must be serving some function other than distributing effluent."

Results of study by Dee Mitchell, "Non-uniform Distribution by Septic Tank Systems":

- "...it was determined that flows less than one gallon per minute could not be uniformly distributed by the commercially available four inch diameter PVC pipe..."
- "The fluid either came out of one hole or all ran to the exit."
- "The surface tension was observed to be sufficient at each hole to prevent fluid from exiting."
- "...the liquid just flowed on each side of the hole...Any time surface tension was broken, all the liquid flowed out of the hole."
- "Poor distribution also occurred in the 4" diameter pipe even at a flow rate of 2.5 gpm..."
- "The fluid exited through only three of the nine holes ..."
- "...with this type of pipe, only the first 10-15 feet of a 60-100 foot lateral will receive septic tank effluent."
- "Even with dosing, uniform distribution in the lateral lines cannot be achieved using commercially available 4" diameter pipe."

Results of a study by Otis et al, "Effluent Distribution":

- "Many different distribution network designs have been used in a soil absorption system all with the intent of uniformly applying liquid...This is rarely achieved..."
- "Very poor distribution resulted with most of the water leaving the pipe at the inlet."
- "...when water was pumped in this pipe at a rate of 13 gpm, 97% of the water was distributed over 53% of the bed..."
- "Rotating the pipe 180 degrees...Gravity distribution through a 4" pipe with one row of holes at the crown gave poor distribution..."
- "The results indicate that the function of the 4" perforated pipe is merely to convey the effluent to the trench or bed."
- "Laying the pipe at a prescribed uniform slope and spacing is of no value because the effluent will exit the hole of lowest elevation."
- "Dosing does not greatly improve distribution because of the large number of holes."

References:

Machmeier, R.E. and J.L. Anderson, "Flow Distribution by Gravity Flow in Perforated Pipe," Onsite Wastewater Treatment: Proceedings of the Fifth National Symposium on Individual and Small Community Sewage Systems, American Society of Agricultural Engineers (St. Josephs, MI, 1988), pp. 224-231.

Mitchell, Dee, "Non-Uniform Distribution by Septic Tank Systems", Arkansas On-Site Domestic Wastewater Renovation Project (Fayetteville, Arkansas: University of Arkansas, 1983).

Otis, R.J., J.C. Converse, B.L. Carlile, and J.E. Witty, "Effluent Distribution," Proceedings of the Second NHSTS, American Society of Agricultural Engineers (1977), pp. 61-85.

INFILTRATOR[®]

SYSTEMS INC

Environmental Onsite Wastewater Solutions

www.infiltratorsystems.com

1-800-221-4436

U.S. Patents: 4,759,661; 5,017,041; 5,156,488; 5,336,017; 5,401,116; 5,401,459; 5,511,903; 5,716,163; 5,588,778; 5,839,844 Canadian Patents: 1,329,959; 2,004,564 Other patents pending. Infiltrator, Equalizer and SideWinder are registered trademarks of Infiltrator Systems Inc. Infiltrator is a registered trademark in France. Infiltrator Systems Inc. is a registered trademark in Mexico. Contour, MicroLeaching, PolyTuff, ChamberSpacer, MultiPort, PosiLock, Quick4, QuickCut, QuickPlay, SnapLock and StraightLock are trademarks of Infiltrator Systems Inc. © 2005 Infiltrator Systems Inc. All rights reserved. Printed in U.S.A.

RESEARCH SUMMARY

“Surface Failure Rates of Chamber and Traditional Aggregate-Laden Trenches in Oregon”

June 2005

Oregon field study shows no statistical difference in failure rates between chambers installed with 50% basal area reduction and natural aggregate

Figure 1: Oregon Eastern (Deschutes) and Western (Clackamas) Study Areas (in green)

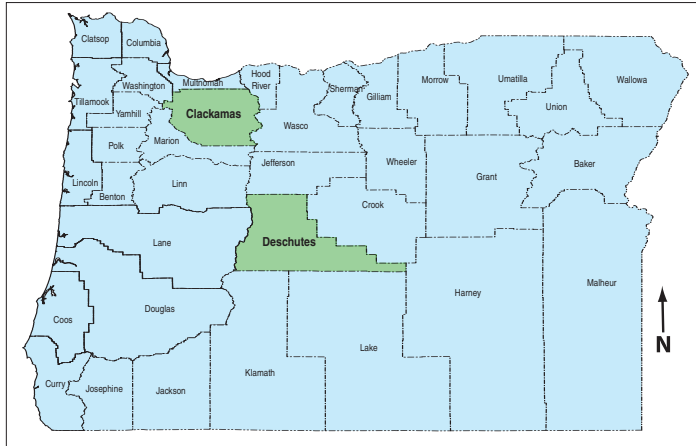

A field assessment was conducted to determine whether Infiltrator® Systems’ Equalizer® 24 chambers (15"W x 12"H) performed equivalent to traditional natural aggregate trenches (24"W x 12"H). As part of this study, a total of 398 wastewater soil absorption systems were evaluated within two physiographic provinces/climates in Oregon (Figure 1: West - humid/temperate, East - semi-arid/high desert), and within a range of soil permeabilities (defined as low, medium and high) (Table 1). For 198 Equalizer 24 chamber systems and 191 natural aggregate trench systems, hydraulic failure rates for both system types were less than 2 percent (Table 2). Onsite systems included in the study were an average of 4 years old, varying in age from 2.9 to 5 years (Table 3), and sized at a 50% sizing reduction compared to aggregate systems (see opposite side for discussion). Results of the study indicate that there was no statistically significant difference in hydraulic failure rates between the two technologies. The study provides an assessment of real-life performance for chamber technology outside the laboratory, demonstrating that chamber systems provide performance reliability that is consistent with conventional aggregate technology.

Table 1: Distribution of Randomly Selected System Sites

Permeability	West region		East region	
	Chamber	Aggregate	Chamber	Aggregate
High	0	0	74	77
Moderate	36	36	39	38
Low	70	70	0	0
Total	106	106	113	115

Table 2: Hydraulic Function Statistics for Equalizer 24 Chamber and Natural Aggregate Trenches

	Chamber Trench		Natural Aggregate Trench	
	Number of Failed Systems	Number of Systems	Number of Failed Systems	Number of Systems
Soil Permeability				
High	1	39	0	44
Moderate	0	71	2	74
Low	1	88	1	73
Region				
West	1	99	2	91
East	1	99	1	100
Totals	2	198	3	191

How did chamber and aggregate failure rates compare?

- Hydraulic failure rates for both system types were less than 2%
- No statistically significant difference in failure rates was identified between the two technologies

How many systems hydraulically failed?

- Equalizer 24 chamber – 2 failures out of 198 total systems (1.0%)
- Natural Aggregate – 3 failures out of 191 total systems (1.6%)

What criteria were used to define a system failure?

- Hydraulic failure was defined as surface discharge of sewage on the ground surface at the time of evaluation

What was the size of the chamber vs. aggregate systems?

- Chamber systems were installed 50% percent smaller than aggregate trench systems

Were both system types installed in different soil types?

- Yes, installations were in low, medium and high permeability soil

Who conducted the study and why?

- Work was performed by experienced on-site wastewater scientists from The On-Site Corporation and Cpec Environmental, Inc., working with the Oregon Department of Environmental Quality (ORDEQ) and local county regulators
- The study was conducted as part of Infiltrator Systems’ Equalizer 24 product approval in Oregon and at the request of the ORDEQ

Has the research been peer reviewed?

- Yes, the information was published in *Small Flows Quarterly* as a juried article (citation shown at bottom of page)

Table 3: System Age by Type and Location

Region	EQ24	Gravel	Total
West	99	91	190
East	99	100	199
Total	198	191	389
Avg. Age (yrs.)	3.8	4.0	4.0
Age Range (yrs.)	2.9-4.8	2.9-5.0	2.9-5.0

“Surface Failure Rates of Chamber and Traditional Aggregate-Laden Trenches in Oregon”

System Size Versus Performance Characteristics

Table 4: Minimum Length of Equalizer 24 Chamber Trench Required for a Four Bedroom Home

State	Length of Equalizer 24 Chambers Required for a 4 Bedroom System (feet)	State Soil Description	Equalizer 24 Approval Description
Oregon	300	Soil Group B	Equivalent to 24" Aggregate Trench
Maine	234	Medium	4.0 square feet/linear foot
Idaho	333	B-2 (Loam, Silt Loam)	Equivalent to 24" Aggregate Trench
Kentucky	346	Soil Group 2 - Loam	Equivalent to 24" Aggregate Trench
New York	433	30 mpi	Equivalent to 24" Aggregate Trench
Illinois	464	30 mpi	2.5 square feet/linear foot

Source of System Sizing Differences

Chamber system sizing criteria vary between regulatory jurisdictions in the United States and Canada. These variations translate to differences in the minimum length of systems constructed using the Equalizer 24 and other chamber models. The primary source of sizing differences is the magnitude of the sizing reduction allowed under the applicable regulations.

Scientifically, a chamber system that is 40 percent as large as a natural aggregate system provides approximately equal open trench bottom area to natural aggregate. This equates to a 60 percent sizing reduction. State and county regulators build factors of safety into regulations by allowing sizing reductions that are comparatively less than the proven maximum. In the United States, typical sizing reductions for chambers are 40 percent, as compared to the 60 percent proven maximum.

Table 4 exemplifies the range of sizing that occurs between states where the Equalizer 24 chamber is approved for use. Sizing shown in the table is based on similar soil permeabilities, and a four bedroom home. As a result, differences in system size result from jurisdictional differences in the allowable reduction for chamber systems, as well as differing soil loading rates and assumed design flow rates.

State Sizing Comparison and Performance

As shown in **Table 4**, the minimum number of linear feet of chamber required for a 4-bedroom chamber system ranges between 234 feet (Maine) and 464 feet (Illinois). By comparison, statistical analysis shows that the hydraulic performance of a 300-foot-long Equalizer 24 chamber system in Oregon provided performance reliability in line with a natural aggregate trench system. Hydraulic failure rates for both system types in Oregon were less than 2 percent, even though chamber trenches had 50 percent less basal area than natural aggregate systems.

The Oregon field performance study data demonstrate that chamber systems installed at reduced sizing compared to traditional natural aggregate systems provide a level of reliability that is consistent with traditional aggregate. Further, chamber systems in Oregon are generally sized with smaller basal areas than other states, such as Idaho, Kentucky, New York, and Illinois. If using Oregon sizing as a baseline, where performance is shown to be acceptable, additional basal area translates to added factor of safety against system hydraulic failure.